

# Special Applications

Threading tools - Utensili per filettare - Outils de filetage

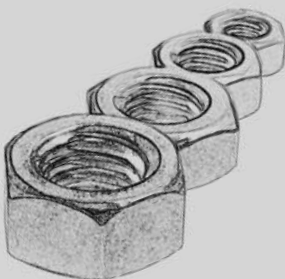
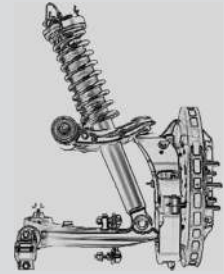
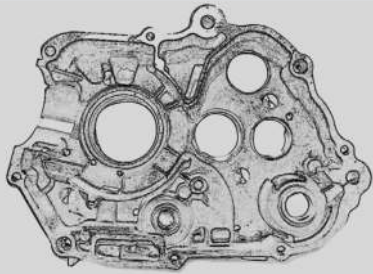
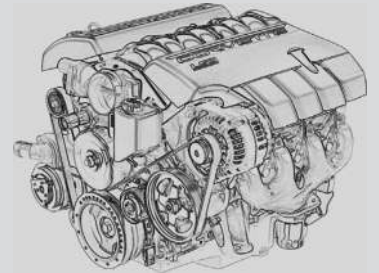
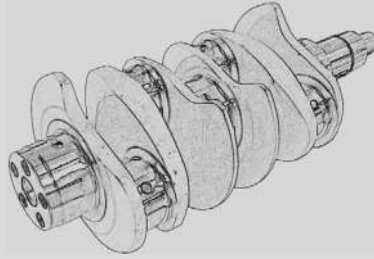

## Oil filters

*Filtri olio*  
*Filtres à huile*

Pag. 4-5



## Engines

*Motori*  
*Moteurs*

Pag. 6-7



## Crankshaft

*Albero motore*  
*Vilebrequins*

Pag. 8



## Gearbox and case

*Scatola cambio e carter*  
*Carter moteur et boîte de vitesses*

Pag. 9



## Connecting rod

*Bielle*  
*Bielles*

Pag. 10



## Steering and suspension group

*Gruppo sterzo e sospensioni*

*Pilotage et ressorts*

Pag. 11



## Wheel hubs

*Mozzi ruota*

*Moyeux de roue*

Pag.12



## Wind energy

*Eolico*

*Énergie éolienne*

Pag. 13



## Bike parts

*Componentistica per biciclette*

*Pièces pour vélos*

Pag. 14-15



## Tractor parts

*Componentistica per trattori*

*Composants pour tracteurs*

Pag. 16



## Nuts

*Dadi*

*Écrous*

Pag. 17



# OIL FILTERS



Fig.1



Fig.2

UFS can suggest you the right product for machining oil filters plates.

Roll form taps (Fig.2) are more and more replacing the standard taps (Fig.1) achieving higher productivity and precision. The most popular diameters are listed in the below table with the best UFS solutions tested in our Technology's Department and developed with our big Automotive partners.

*La UFS, con lo studio ed i test della UFS Technology, ha evoluto negli anni il prodotto specifico per la filettatura della piastra di attacco del filtro olio per vetture, camion e trattori. L'esecuzione ad asportazione di truciolo (Fig.1) è stata in gran parte sostituita con quella a deformazione – Maschi a Rullare – (Fig.2) con maggiore produttività e qualità di prodotto ottenuto. La tabella qui di seguito riportata dà un'indicazione dei diametri più richiesti, con le dimensioni adottate dalla UFS. Materiale, spoglie, tolleranze e rivestimenti sono frutto della continua evoluzione, test e collaborazione tecnica con Clienti del Settore Automotive che qui abbiamo occasione di ringraziare!*

*Le UFS, au travers des études et des essais de l' UFS Technologie, a évolué au cours des années, le produit spécifique pour le taraudage de la plaque de fixation du filtre à huile pour voitures, camions et tracteurs. L'exécution avec l'enlèvement de copeaux (Fig.1) a été en grande partie remplacé par la déformation – Tarauds à Refouler – (Fig.2) pour une augmentation de la productivité et la qualité des produits obtenus.*

*Le tableau ci-dessous donne une indication des diamètres les plus demandés, avec des résolutions adoptées par La société UFS. Matière, dépouilles, les tolérances et les revêtements sont le résultat d' une évolution continue, essai et collaboration technique avec les Clients du Secteur Automobile qu'il nous faut remercier !*

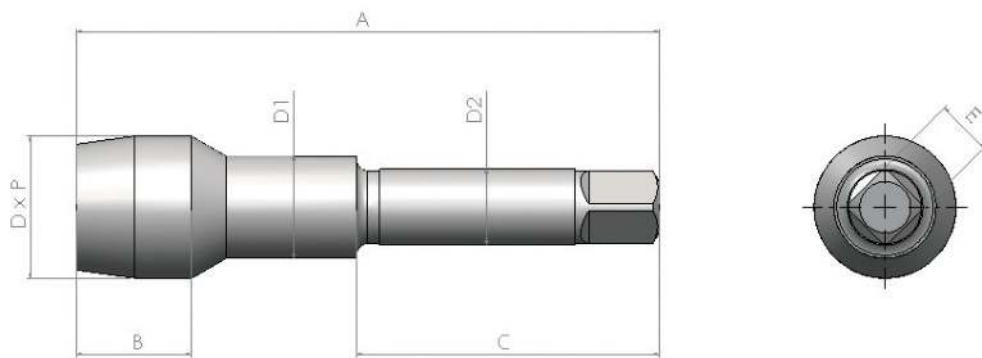

D (mm)	P (mm)	A	B	D1	D2	C	E
16	1,5	100	22	-	12	-	9
20	1,5	125	25	-	16	-	12
22	1,5	125	25	-	16	-	12
30	2	125	25	22	16	65	12

D	P	A	B	D1	D2	C	E
3/4	16	125	25	-	16	-	12
13/16	16	125	25	-	16	-	12
1"	14	125	25	-	16	-	12
1"	12	125	25	-	16	-	12
1"-1/8	16	125	25	22	16	65	12
1'-1/2	12	125	25	28	16	65	12

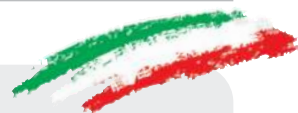

Cylinder head, aluminum.

*Testa cilindri, alluminio.*

*Culasse d'aluminium.*

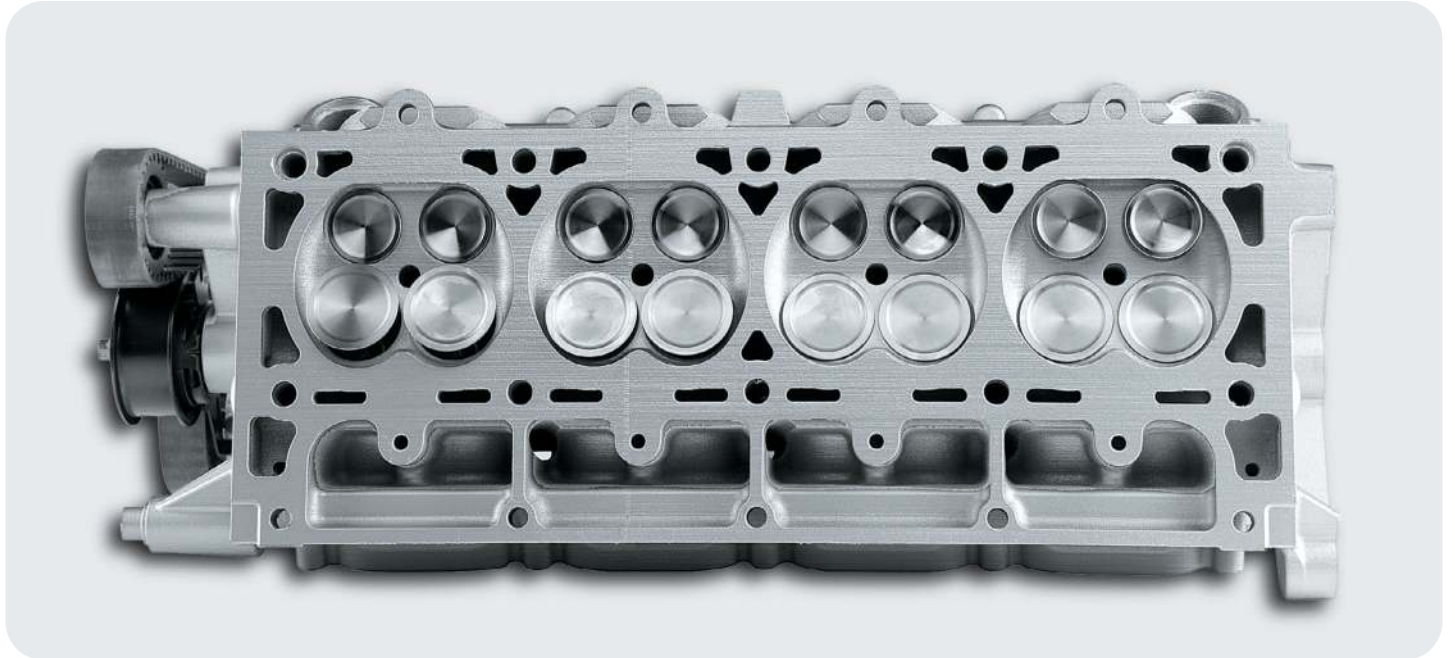

High performance coated taps are required in these operations.

Roll form taps are always more adopted.

*Per le lavorazioni sopra riportate si richiedono maschi ad alto rendimento in abbinamento a particolari rivestimenti. Anche in questo ambito i maschi a rullare stanno giocando un ruolo sempre più importante.*

*Pour le travail ci-dessus il est nécessaire d'avoir des tarauds de haute performance en combinaison avec des revêtements spéciaux. Les tarauds à rouler occupent un rôle des plus en plus important dans ce domaine.*



Cylinder block, cast iron.  
*Blocco motore, ghisa.*  
*Bloc moteur en fonte.*

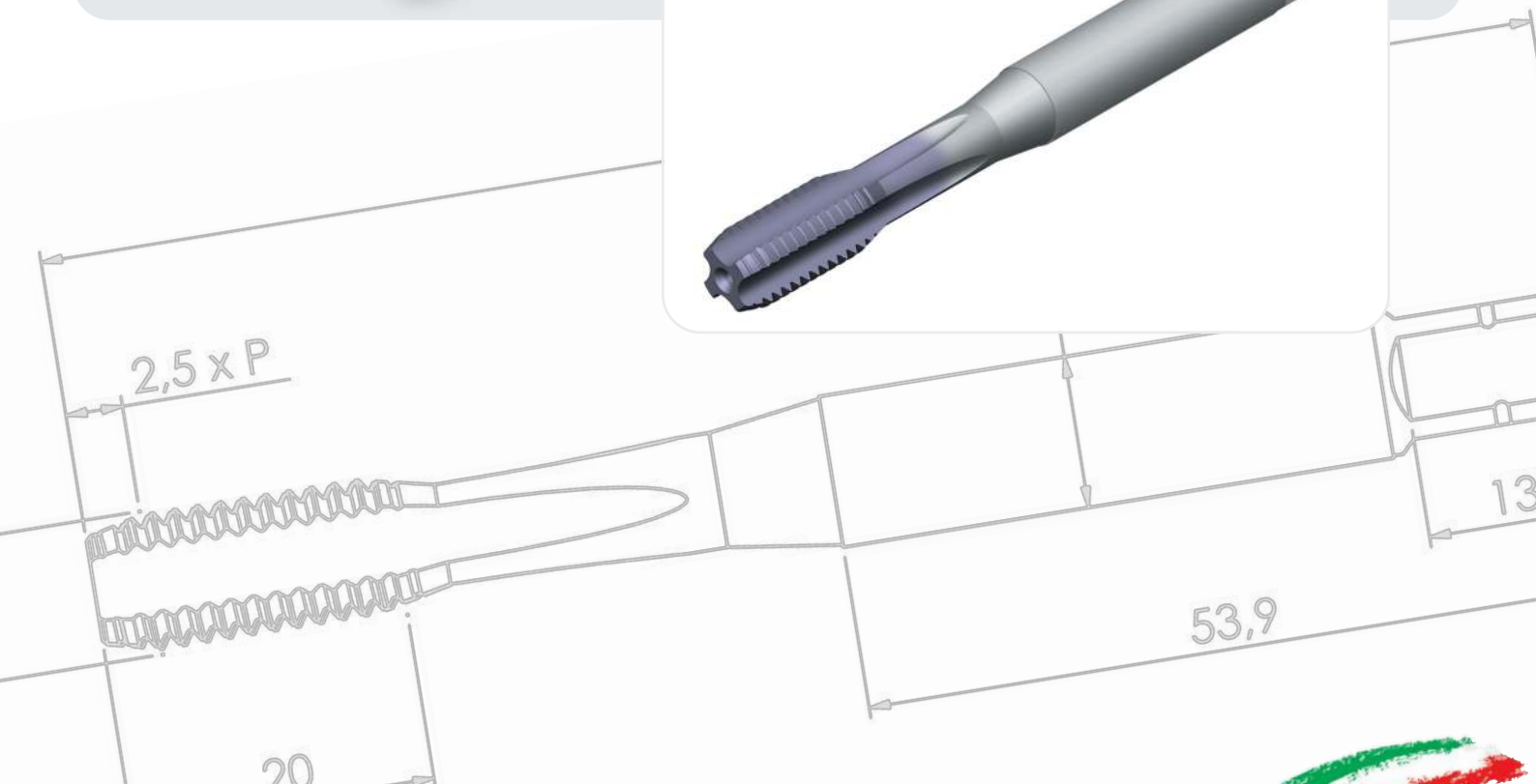
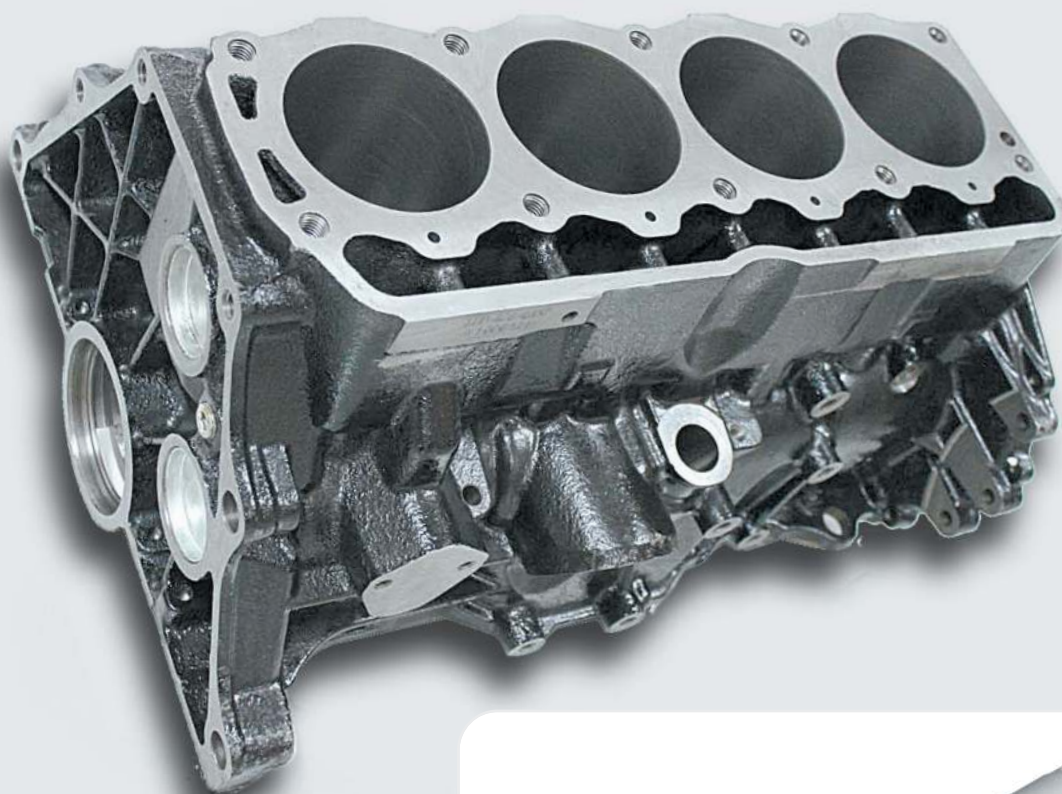

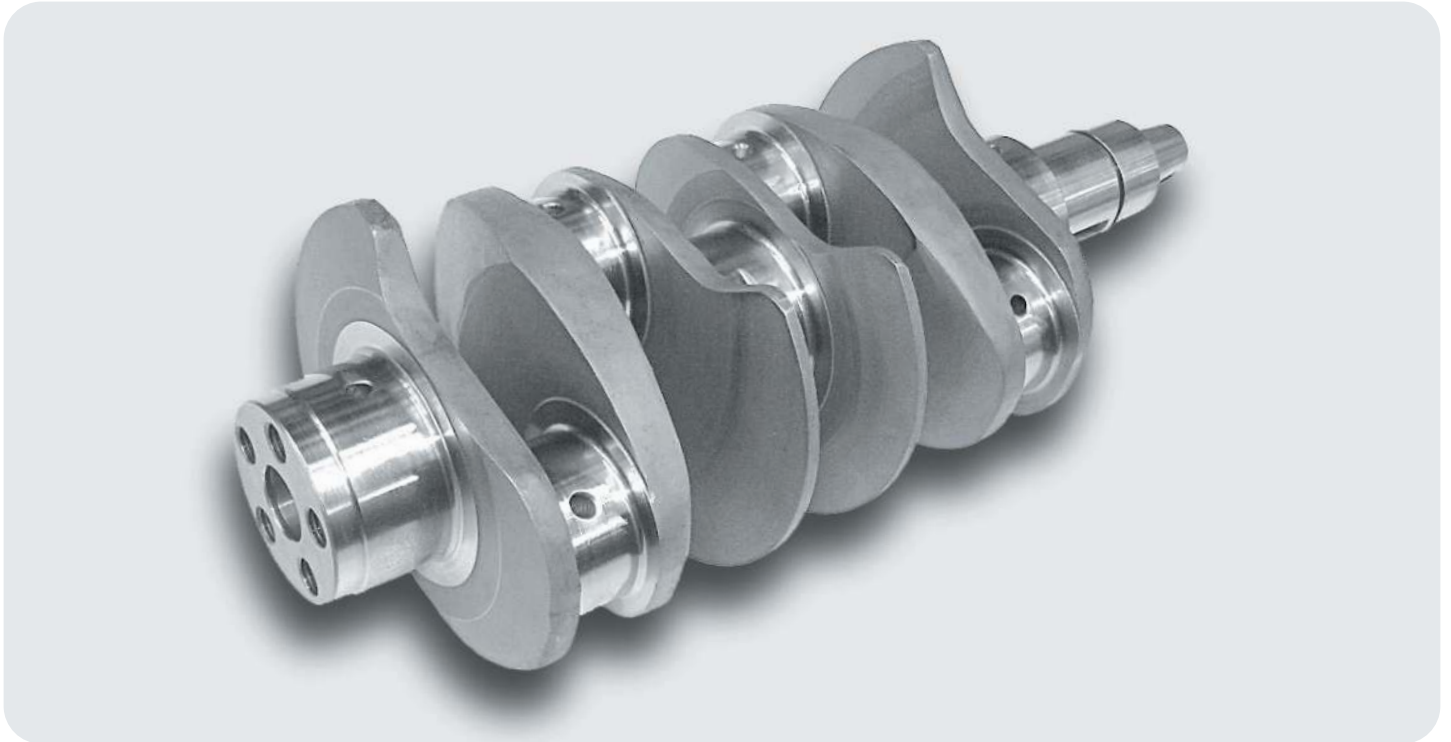

The horizontal machining of the crankshaft may be a difficult operation that required customized taps to better break the chip. UFS can provide you the right tool.

*La filettatura degli alberi motore con la necessità di rompere il truciolo in filettatura orizzontale è un'operazione gravosa ed può aver bisogno di maschi con lunghezza totale maggiore dello standard.*

*La UFS dispone della necessaria esperienza e tecnologia per fornire maschi validi in questo settore importante dell'Automotive.*

*Le taraudage de vilebrequin en horizontal est profond, il nécessite une évacuation des copeaux et peut exiger des tarauds avec une longueur totale supérieure à la norme. La société UFS possède l'expérience nécessaire et la technologie pour fournir des tarauds valides dans ce secteur de l'Industrie Automobile.*

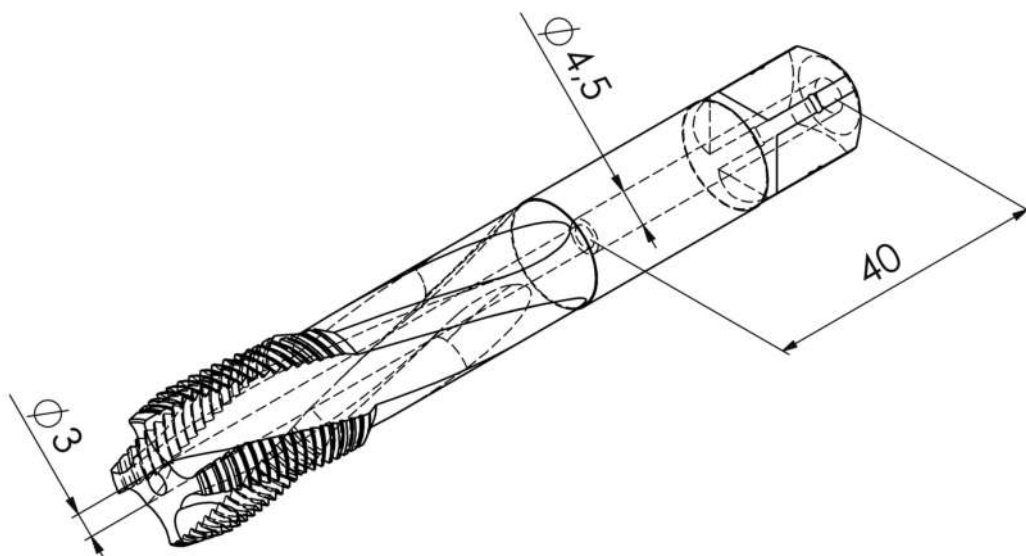



UFS has studied customized taps with special geometry and coating for machining gearbox engine's covers and other parts made of Aluminium casting.

*Applicazioni speciali dedicate alla filettatura delle fusioni di alluminio per l'automotive; in particolare la scatola del cambio, carter motore ed anche altri particolari. Le dimensioni dei maschi sono particolari, con lunghezza totale maggiorata; spoglie e rivestimenti speciali per le fusioni di alluminio.*

*Applications spéciales dédiées pour les pièces moulées en aluminium pour l'industrie automobile ; tout particulièrement, boîte de vitesses, carter ainsi que divers applications. Les dimension des tarauds sont spéciales, avec des longueurs totales plus importantes; sous divers aspects, non revêtus ou revêtements spécifiques adaptés.*

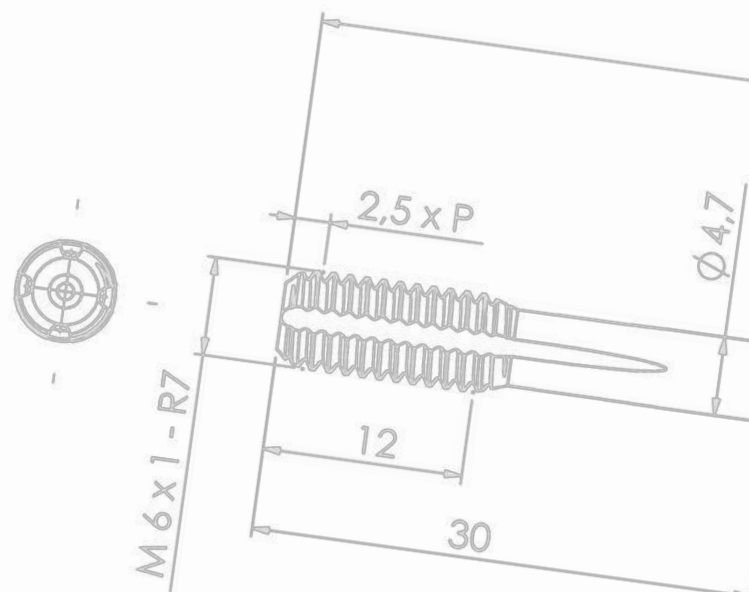



Connecting rods requires an accurate machining to obtain a better resistance.

*Fondamentale il ruolo della filettatura nelle bielle, per precisione e resistenza alla fatica del particolare.*

*Le rôle fondamental du fil des bielles, résistance de précision et à la fatigue du particulier.*

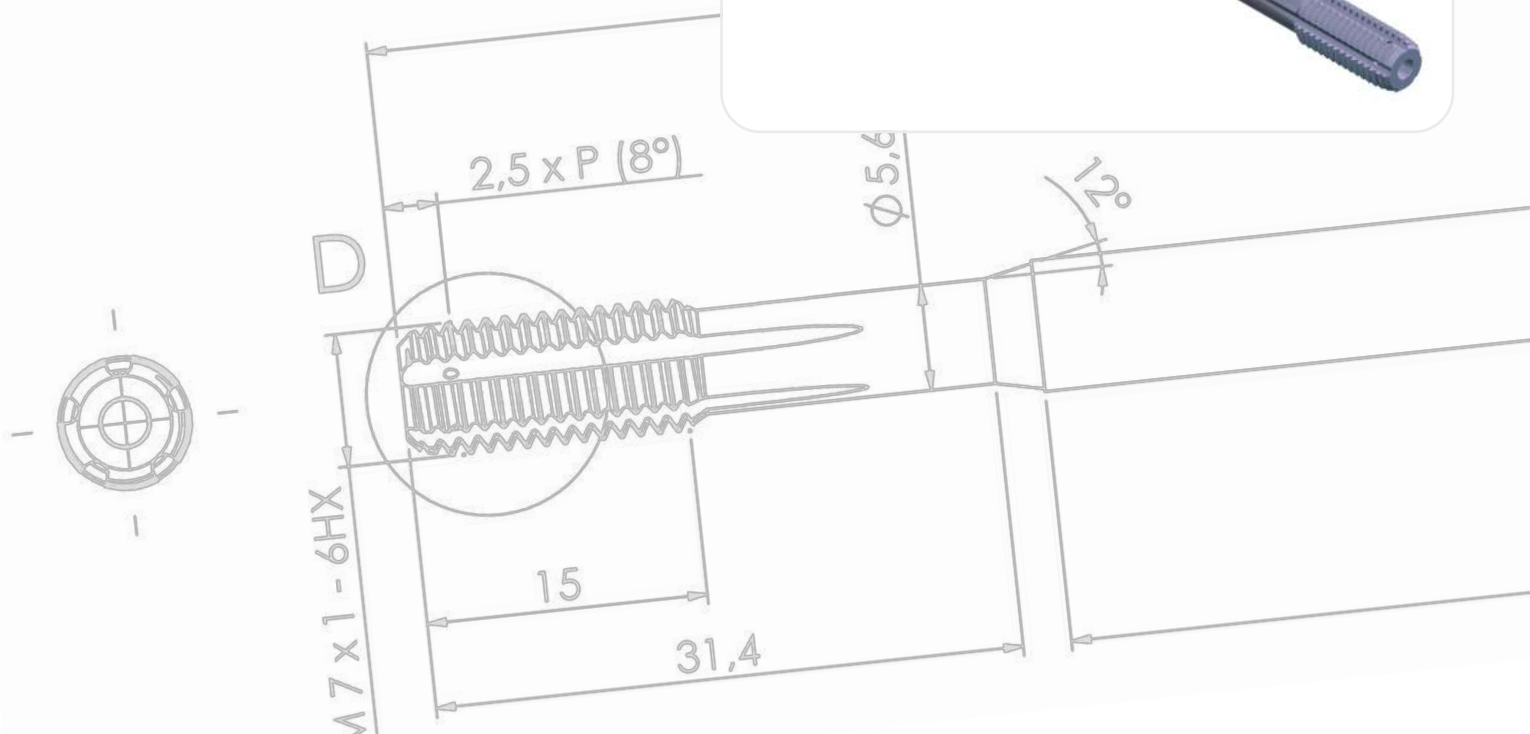

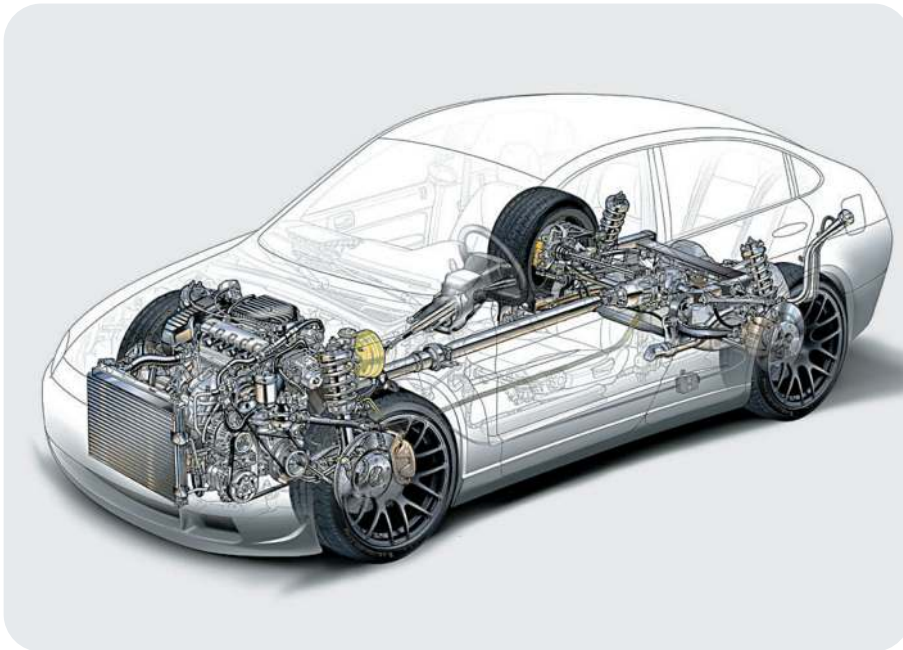

UFS has developed a great experience in the auto parts manufacturing also due to its geographic location near the biggest Italian Industries. Our coating machines can guarantee quality and consistency

*La produzione della componentistica auto è un Settore seguito fin dalla nascita della UFS, per la stessa collocazione dell'azienda nella Regione Piemonte, sede della Grande Industria Auto e di tante altre Aziende minori dello stesso Settore Automotive. La UFS dispone di un impianto di rivestimento interno con cui garantisce cura assoluta dei trattamenti e costanza degli stessi.*

*La production de composants des pièces d'automobiles est un secteur suivi depuis la création de l'UFS, situé dans la région du Piémont, berceau de l'industrie automobile et de l'industrie en général. La société UFS possède ses propres centres de revêtement en interne, ceci est pour le client la garantie d'une qualité constante et d'une grande fiabilité.*

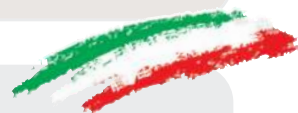



The secret of our efficiency and consistency is the long terms experience in the Automotive Sector and the continuous evolution and professional upgrade from the design until the tests at our partners.

*La collaborazione con i più importanti costruttori di particolari per auto, lo studio e la progettazione con i più recenti sistemi cad-cam, l'analisi dei risultati delle prove interne e presso gli utilizzatori, sono elementi fondamentali per il raggiungimento dell'obiettivo di massima resa e costanza di rendimento.*

*La collaboration avec les principaux fabricants de pièces automobiles, l'étude et la réalisation pilotée par les derniers systèmes cad-cam, l'analyse des résultats de tests internes en collaboration avec les clients finaux sont essentiels pour atteindre l'objectif d'une efficacité maximale et des performances constantes.*

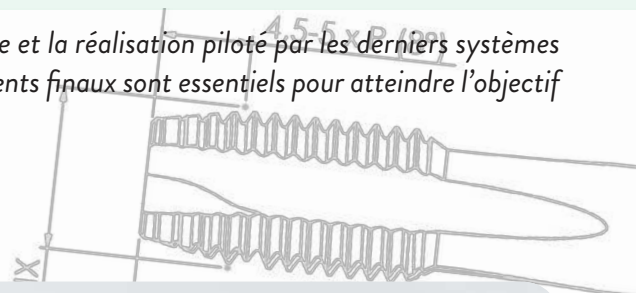



Longer taps with internal coolant and spiral flutes are normally the most common solution adopted in Wind Power Energy Sector.

*In continuo aumento lo sviluppo di applicazioni specifiche per settore eolico. Caratteristiche significative dei maschi utilizzati sono: lunghezza totale del pezzo superiore allo standard, possibilità di avere il passaggio centrale del lubrorefrigerante, eliche a forte torsione con una lunghezza di scarico superiore alla norma.*

*La société UFS augmente le développement d'applications spécifiques pour l'industrie éolienne. Les caractéristiques importantes des tarauds utilisés sont: longueur totale de la pièce supérieure à la norme, possibilité du passage central du liquide de refroidissement, hélices et longueur de goujure importante.*

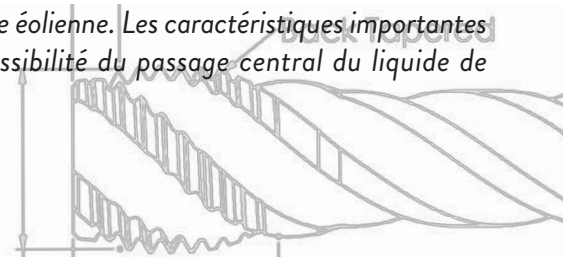

# BIKE PARTS

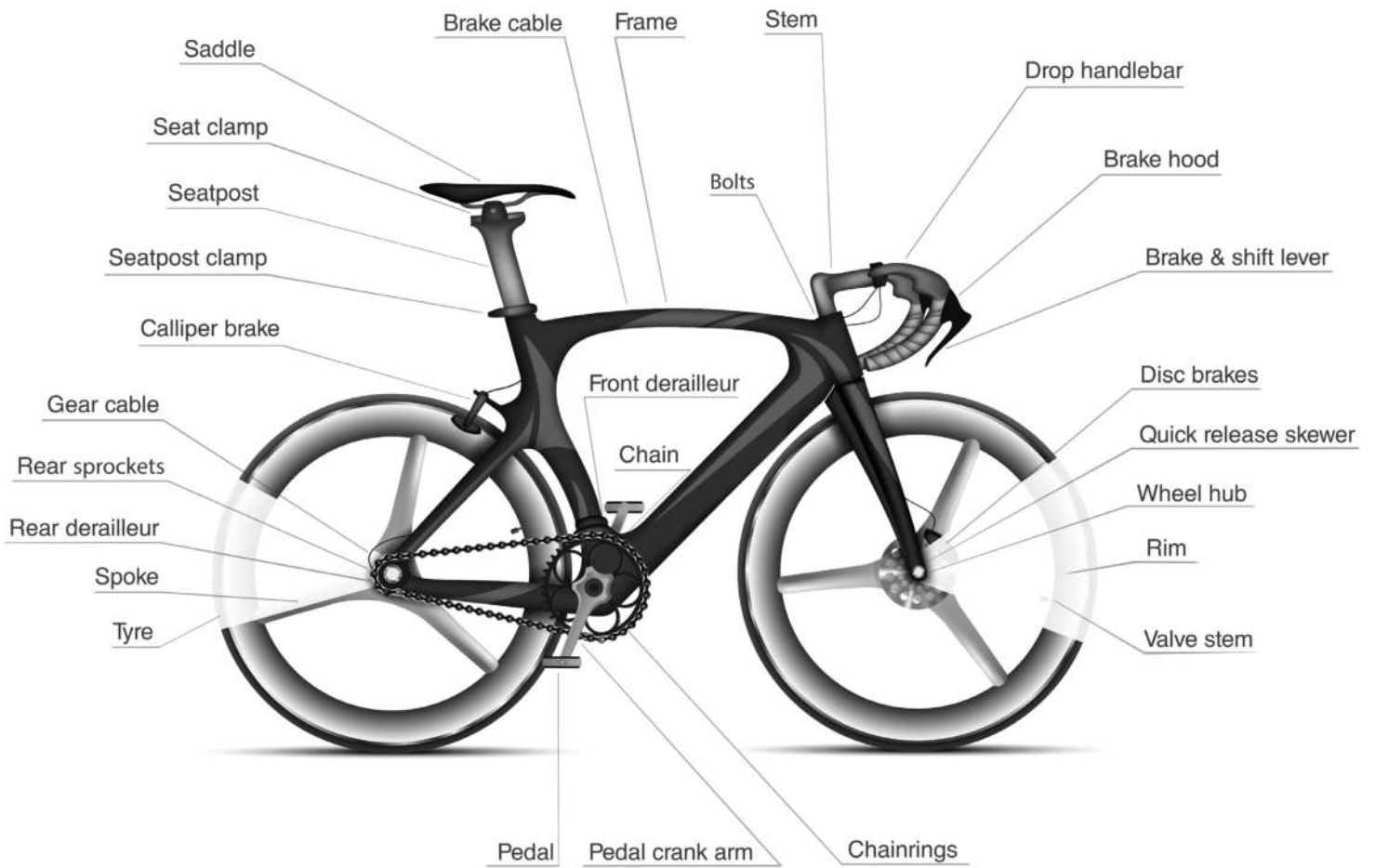



UFS realize customed taps for bike components; in particular:

- Left and right pedals
- Forks

*Realizzazione di maschi specifici per la componentistica per biciclette; in particolare:*

- *Maschi per pedali destri e sinistri*
- *Maschi per la filettatura del forcellino*

*Réalisation de tarauds speciaux; en particulier:*

- *Tarauds pour pédales gauche et droite*
- *Tarauds pour le filetage des pattes de dérailleur*

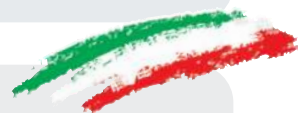

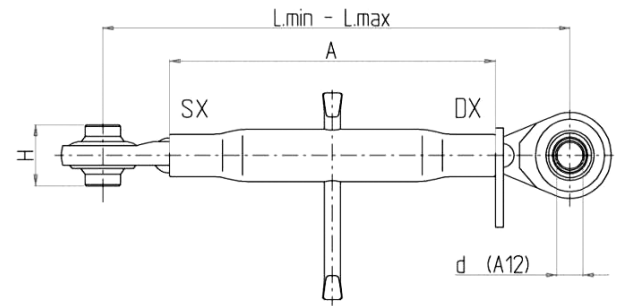
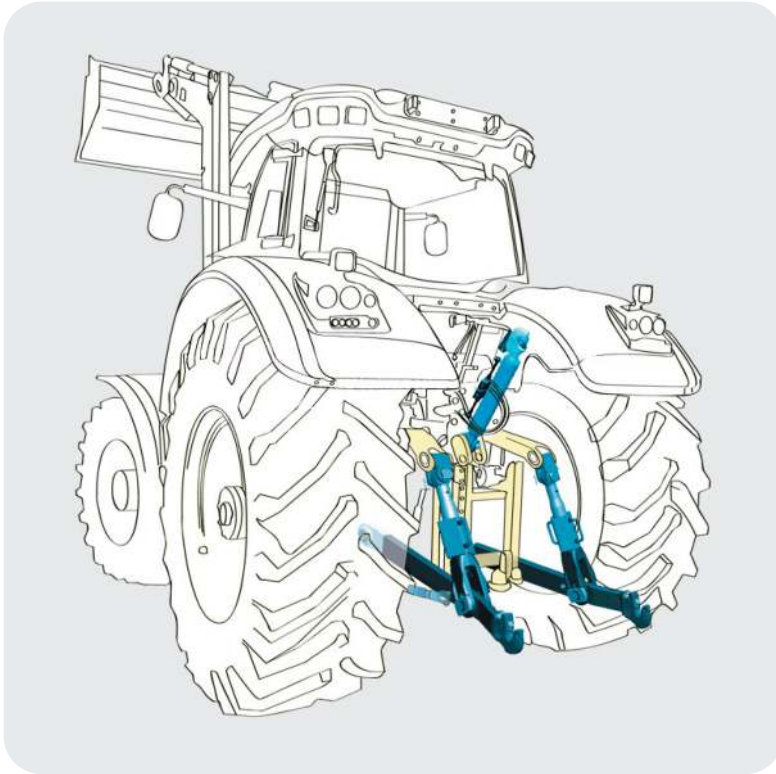

UFS has gained extensive experience in the machining of coupling, towing and lifting implements for agricultural tractors.

*La UFS ha acquisito una elevata esperienza in questo settore con una produzione di maschi speciali dedicati come, per esempio, per la filettatura del tirante che costituisce il "terzo punto".*

*La société UFS a acquis une grande expérience dans ce domaine avec une production spéciale de tarauds, par exemple, pour le taraudage de tige de renfort qui assure la « liaison à trois points ».*





UFS can provide customized taps for threading nuts: different tolerances and screw connection for curved shanks for diameters up to 10 mm.

Maschi per la filettatura dei dadi; realizzabili in diverse modalità di tolleranza, eventualmente anche disponibili con l'attacco a vite per il collegamento con gambo curvo mediante boccia, per diametri superiori a 10 mm. Realizzazione di maschi speciali in base alle singole esigenze.

Tarauts pour les filets des écrous (à l'enfilade); réalisable dans différents tolérances, disponible avec vis pour la connexion avec tige incurvée au moyen de douille, pour les diamètres au-dessus de 10 mm. Réalisation des tarauts spéciaux selon les besoins individuels.





